

SAFETY & WARNINGS

1. Install in accordance with national and local electrical code regulations.
2. This product is intended to be installed and serviced by a qualified, licensed electrician.
3. Do not modify or disassemble this product beyond instructions or the warranty will be void.
4. Do not submerge, or install within 5 feet of a swimming pool.
5. Only install with a Listed Class 2 DC LED driver.
6. To avoid Voltage Drop, ensure wire gauge used with LED Strip Light is sufficient to keep under 3% voltage drop.
7. Do not exceed maximum run recommended for Strip Light.
8. SQUIGGLY™ LED Tape Light is designed to be cut and bent at designated cut and bend points only. Cutting or bending anywhere other than these designated points will result in damage to the Strip Light.
9. Failure to follow safety warnings, and installation instructions will void the warranty for this product.

QUICK SPECS

Input Voltage	24V DC
Power Consumption	2.2W/ft.
Maximum Run	33 ft.
Environment	Indoor

Included Models ¹	DI-24V-SQ2- ^{**}
Ambient Temperature ²	-4° ~ 122°F (-20° ~ 50°C)

Note ¹ ^{**} Indicates luminaire family, CCT, and length.

Note ² Do not install product in an environment outside the listed ambient temperature.

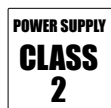
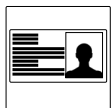

SQUIGGLY™ Flexible LED Tape Light

INSTALLATION GUIDE



WARNING!

DO NOT CONNECT DIRECTLY TO HIGH VOLTAGE POWER!

Read all warnings and installation instructions thoroughly.

HANDLE PRODUCT WITH CARE!

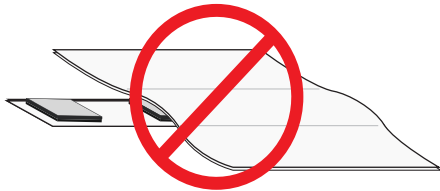

DO NOT COVER STRIP LIGHT WITH ANY MATERIALS.

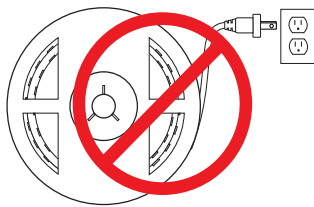

DO NOT POWER STRIP LIGHT WHILE ATTACHED TO SPOOL OR TIGHTLY COILED.

INSTALLATION

Prior to installation, verify all components (LED Tape, Driver, Control, & Accessories) are compatible. Configure and pre-test your LED system prior to installation to ensure all components are operating correctly.

1 TURN POWER OFF AT CIRCUIT BREAKER



SHOCK HAZARD! May result in serious injury or death.

Turn power OFF at circuit breaker prior to installation.

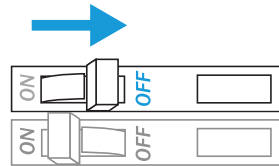

2 DETERMINE LOCATION TO INSTALL COMPONENTS

Refer to **SYSTEM DIAGRAMS**.

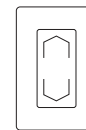
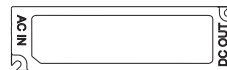

1) Class 2 Driver

2) Control

3) Tape Light

WIRE GAUGE & VOLTAGE DROP

Ensure applicable wire is installed between driver, fixture, and any controls in between. When choosing wire, factor in voltage drop, amperage rating, and type (in-wall rated, wet location rated, etc.)

3 CUT TAPE LIGHT TO DESIRED LENGTH

Cut at line indicated with scissors icon.

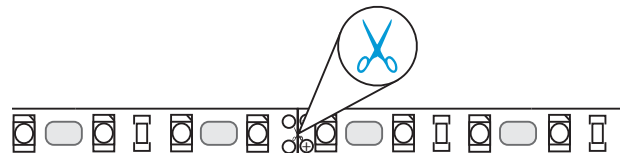

SQUIGGLY™ Flexible LED Tape Light

INSTALLATION GUIDE

INSTALLATION (CONT.)

4 TEST CONNECTION



Prior to mounting, attach to Class 2 LED Driver, turn on power and test connection to ensure system is operating properly. Turn off power again before mounting.

5 MOUNT TAPE LIGHT

Clean surface before mounting.

- 5.1** Peel off 3M™ Adhesive Backing. *Ensure ambient temp is minimum 50° F (10° C) or tape will not adhere properly.*

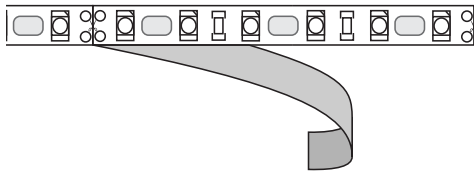

- 5.2** Adhere to a smooth, dry surface, working one end to the other.

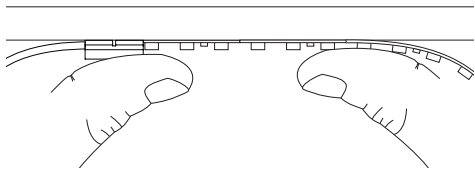

6 BENDING SQUIGGLY 200 TAPE LIGHT

Fold SQUIGGLY 200 LED Tape Light horizontally at any bend point.

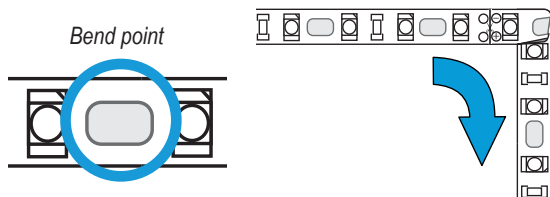

SQUIGGLY 200 Tape Light will fold over itself when bent at the bend point. No additional modification required.

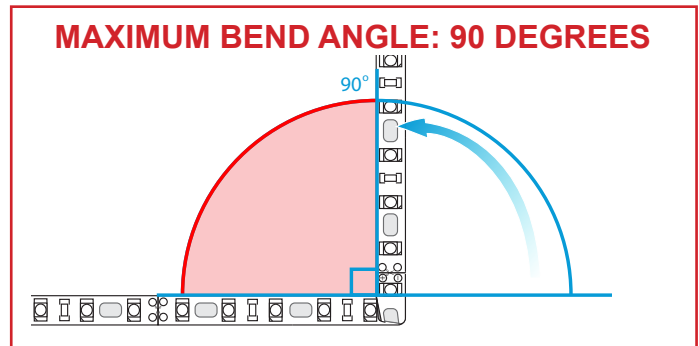
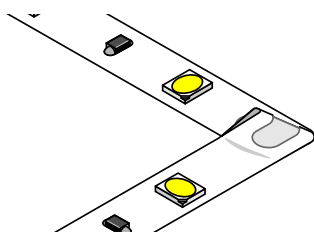

7 ATTACH DRIVER AND LIGHTING CONTROL

ONLY USE COPPER WIRING. See **SYSTEM DIAGRAMS** on page 5. Verify a compatible driver and control are installed.

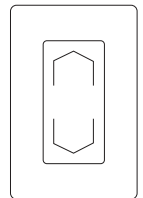
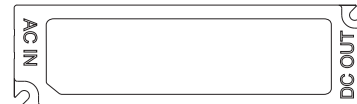

REVIEW FULL SYSTEM and ensure all polarities are correct and connections are secure.

8 TURN POWER ON AT CIRCUIT BREAKER

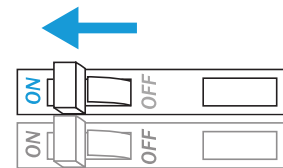

SYSTEM WORKING IMPROPERLY?

Turn power OFF at circuit breaker and verify all connections. Review SYSTEM DIAGRAMS and TROUBLESHOOTING or call Diode LED Technical Support at 877.817.6028.

ADDITIONAL RESOURCES

Visit the on-line product page at www.DiodeLED.com for individual LED Tape Light product specifications & warranty information.

SQUIGGLY™ Flexible LED Tape Light

INSTALLATION GUIDE

SYSTEM DIAGRAMS

The following diagrams are provided as example system designs. For information regarding larger systems or systems not pictured below, please see our web page or contact technical support. Always review each component installation guide for detailed and up-to-date wiring instructions. Install in accordance with national and local electrical codes.

SINGLE COLOR CONTROL SYSTEMS

Traditional ON/OFF Switch System

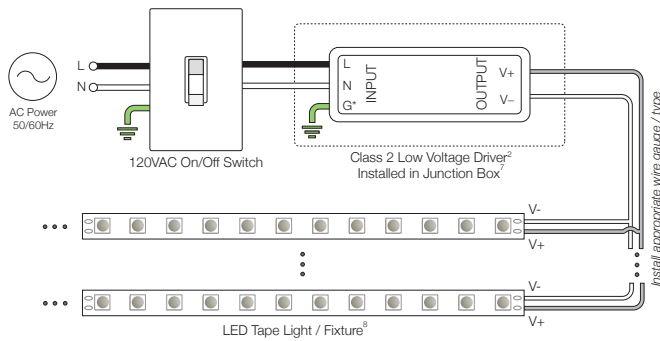

SWITCHEX® Dimmer/Driver System

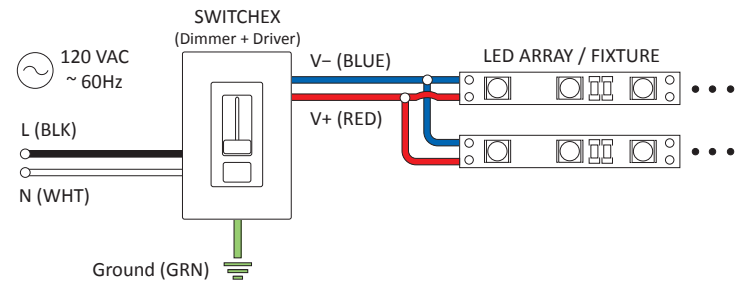

OMNIDRIVE® Electronic Dimmable Driver System

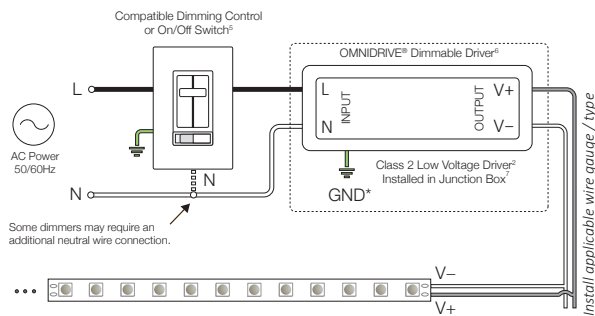

REIGN® 24V Dimmer System

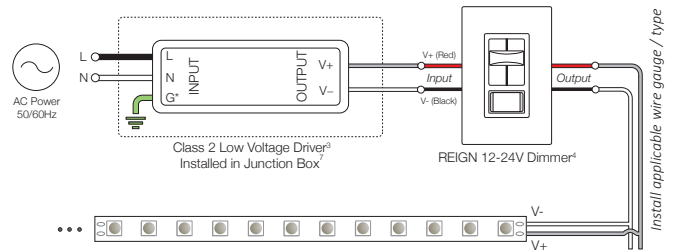

1. Driver may not require a fault ground connection. Refer to driver specifications for additional information.
2. Install a compatible Class 2 constant voltage driver. Refer to each driver specification sheet for full power ratings & load deratings.
3. Install a Class 2 constant voltage driver compatible with a low voltage PWM controller/dimmer switch. Refer to each driver specification sheet for full power ratings & load deratings.
4. Determine the number of low voltage outputs of the driver when installing multiple PWM controllers/dimmer switches. No more than one PWM controller/dimmer switch can be attached to a single output of the driver.
5. Install a compatible dimming control or switch. See the 'Electronic Dimmable Driver / Dimmer Compatibility List' for compatible dimming controls. See the dimming control manufacturer installation guide for complete wiring instructions.
6. Ensure to load the driver at least 60% of the labeled load for proper dimming performance (required for dimmable installations only).
7. Refer to driver or controller specifications for a compatible junction box.
8. See fixture specifications for maximum series run limits.

SQUIGGLY™ Flexible LED Tape Light

TROUBLESHOOTING

Symptom	Common Cause
Tape Light does not illuminate	<ul style="list-style-type: none">• Circuit breaker is OFF or tripped.• Incorrect wiring. Polarity of Low Voltage V+ and V- are reversed. Check connection at every connection point to ensure polarity is not reversed.• Incorrect voltage pairing of LED driver and fixture. 24V driver models will not power a fixture with a higher voltage rating.
Fixture flickers randomly, may shut off	<ul style="list-style-type: none">• Connection is not secure. Check connection at CLICKTIGHT and ensure metal prongs of CLICKTIGHT are directly on top of Tape Light Solder pads.
Shift in brightness and/or color	<ul style="list-style-type: none">• Review Tape Light maximum series run limit. Exceeding will cause voltage drop, decreasing brightness and/or color shift.• Review Voltage Drop Charts on pg. 8. Incorrect wire gauge may cause voltage drop and noticeable shift in brightness and/or color.
Tape Light turns on/off repeatedly	<ul style="list-style-type: none">• Driver is overloaded or overheated. An overloaded/overheated driver will trip the internal auto-reset (of driver) repeatedly, turning the system on/off.
CLICKTIGHT Connectors	<ul style="list-style-type: none">• Ensure compatible CLICKTIGHT models are attached. Tape lights vary in width and require specific connectors. Contact your supplier for additional information.• Tape Light is polarity sensitive. Ensure V+ of power is attached to V+ of tape light. Ensure V- of power is attached to V- of tape light.

VOLTAGE DROP CHARTS

For best performance and lumen output, ensure proper wire gauge is installed to compensate for voltage drop of low voltage circuits.

Voltage Drop Chart Guide

- 1 Determine load size.
(example: Let's assume load is 55 W. Round up to nearest load)
- 2 Determine distance from driver to load.
(example: Let's assume the distance is 20 ft.)
- 3 Determine AWG of wire to be used.
(example: With 55 watt load, 20 feet away, it is recommended to install 12 AWG to eliminate excess voltage drop)

24V Voltage Drop & Wire Length Distance Chart (3% Drop or 23.28V)*

WIRE GAUGE	10 W .42 A	20 W .83 A	30 W 1.3 A	40 W 1.7 A	50 W 2.1 A	60 W 2.5 A	70 W 2.9 A	80 W 3.3 A	90 W 3.75 A	100 W 4.2 A
20 AWG	85 ft.	43 ft.	27 ft.	21 ft.	17 ft.	14 ft.	12 ft.	11 ft.	9 ft.	8 ft.
18 AWG	134 ft.	68 ft.	45 ft.	33 ft.	27 ft.	22 ft.	19 ft.	17 ft.	15 ft.	14 ft.
16 AWG	215 ft.	109 ft.	72 ft.	54 ft.	43 ft.	36 ft.	31 ft.	27 ft.	24 ft.	22 ft.
14 AWG	345 ft.	174 ft.	115 ft.	86 ft.	69 ft.	57 ft.	49 ft.	43 ft.	39 ft.	36 ft.
12 AWG	539 ft.	272 ft.	181 ft.	135 ft.	108 ft.	90 ft.	77 ft.	68 ft.	61 ft.	56 ft.
10 AWG	784 ft.	397 ft.	263 ft.	197 ft.	158 ft.	131 ft.	112 ft.	98 ft.	97 ft.	82 ft.